

Building a Deck?

Things You Should Know First

General Information

A deck is any structure with its top of floor being 200 mm or more above grade.

Deck construction is regulated by the National Building Code (2005) and placement of decks are governed by Municipal Zoning Bylaw No. 14/2003.

A building permit is required to construct a new deck, demolish, repair or alter an existing deck, or enclose (or roof over) an existing deck in residential areas of the city.

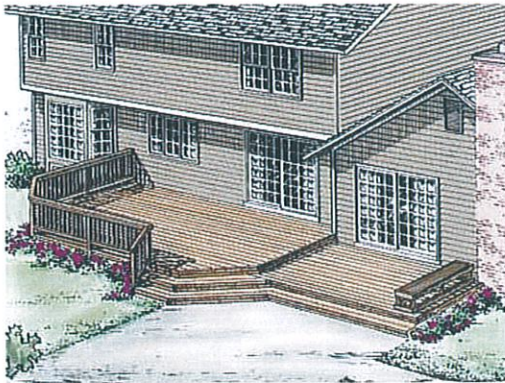

National Building Code

Building Code Requirements detailed in the National Building Code of Canada concerning guardrails, handrails, stair construction, come in effect and must be considered when planning the structure of decks and foundation support requirements where in piles will be required when the distance from finished ground to the underside of the joists exceeds 600mm.



Required Inspections

A deck may be inspected several times during the construction to ensure that structural and safety codes have been addressed.

Allowable Encroachments

Decks more than 0.4 m above grade cannot project more than 1.8 m into the required front yard.

Decks more than 0.6 m above grade may encroach into the required side yard not more than 1.8 m and may not encroach more than 25% into the width of the required side yard whichever is less.

Decks more than 0.6 m above grade may encroach a maximum of 3 m into the required rear yard setback.

Information Required with Permit Application

Site plan showing the house and proposed deck with distances shown to property lines and accessory buildings.

A plan showing the location and size of piles, beams, and columns.

A cross-section of the deck structure showing materials to be used and the height above grade.

Any structural changes to the dwelling unit resulting from the deck location (ie. installation or relocation of patio door).

Civic address and legal description.

Call Before You Dig!

Before excavating or drilling holes it is advised that you contact the following utility providers for line locates.

Sask First Call 1-866-828-4888
Access Comm. 786-1566

This pamphlet is published by the City of Yorkton and has no legal status as an official interpretation of the various codes, regulations, bylaws or statutes currently in effect with regard to construction or the offering for sale of any property by the City of Yorkton. Users are advised to contact the Building Services division for assistance as the City of Yorkton accepts no responsibility to persons relying solely on this information.

Date of Revision: September 10, 2010

DECKS

Supplement to Building Permit Application

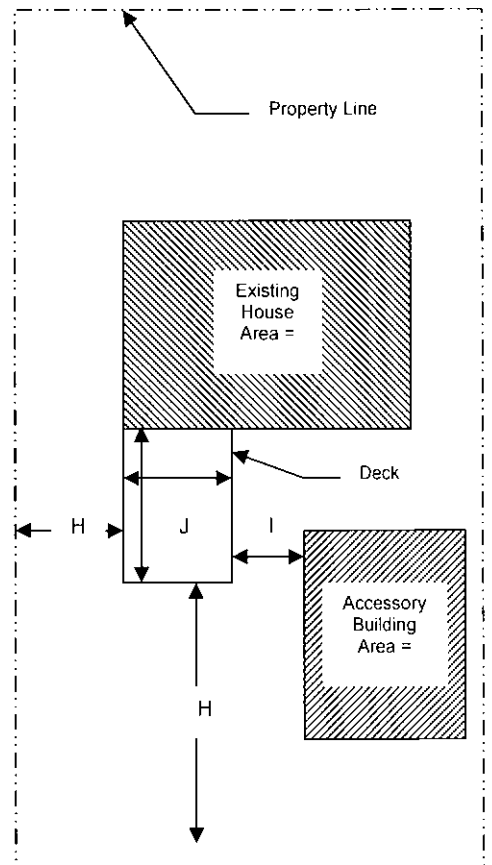
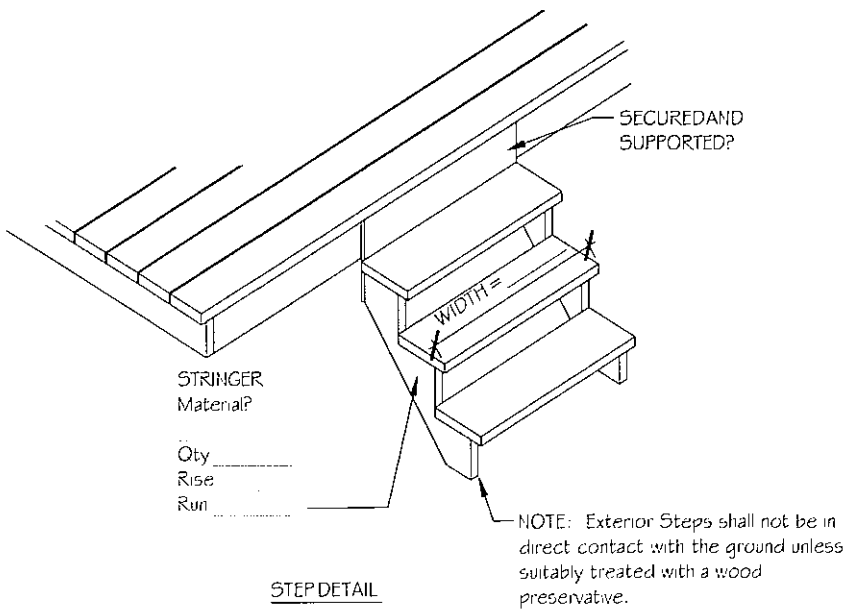
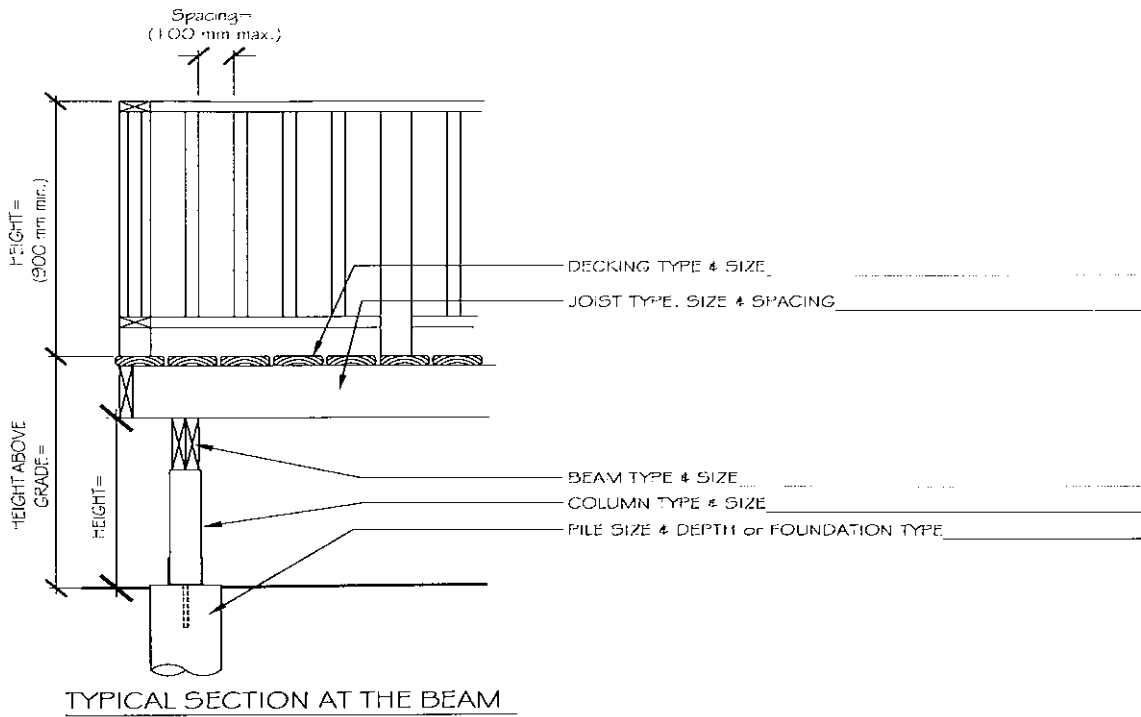

Example